



# KAPO BOARD TECHNICAL & INSTALLATION MANUAL

2020 November

**BRANZ Type Test**  
Type Test No. FH5551-TT [2014]



# CONTENTS

INTRODUCTION	1
COMPLIANCE	1
SCOPE OF LIMITATION	2
KAPO BOARD SIZE	2
EDGE TYPES	2
ESSENTIAL COMPONENTS	3
ACCESORIES	3
VERIFICATION OF COMPLIANCE	4
VERIFICATION OF NEW ZELAND BUILDING CODE (NZBC) PERFORMANCE CRITERIA	5
OTHER INVESTIGATIONS	5
STORAGE HANDLING	6
SAFE WORKING PRACTICES	6
WORKING INSTRUCTION	7
PRODUCT FEATURES	7
INSTALLATION	8
Framing	9
Typical Wall Layout (untiled)	9
Typical Wall Layout (tiled)	10
Fixings	11
Fixing on steel framing	11
Structural Bracing Wall	12
Typical Sheet Layout	15
Partition and Existing floor	17
Concrete ceiling partition wall + Suspension Ceiling	18
L-Corner Joint Cross Section	19
“T” section	20
Typical Ceiling Layout	21
FINISHING	22
Recessed Edge Joint	23
Squared Edge Joint	24
Internal Corners	25
External Corners	26
Typical Finishing for internal wall	27
Typical Finishing for internal wall with Mesh	28
Dulux coating	29
Product Warranty	28

## INTRODUCTION

Enviro Square Limited was established to promote the use of environmentally friendly building materials and create a better living environment with one of the more advanced building material in New Zealand.

Enviro Square's KAPO Board is well known in the Chinese market. The product is used in many European countries such as Italy, Sweden, Norway, Russia, UK, Spain and Poland.

In recent years Enviro Square has set up close relationships many customers in New Zealand. The reliable quality and value of the products have earned KAPO Board recognition and favour in both commercial and residential markets.

## COMPLIANCE

KAPO Board has been assessed against New Zealand building code requirement and compliance has been verified under BEAL's Appraisal, C820. It meets performance clauses of B1, B2, C3, E2, F2 and G6.

Additionally, KAPO Board has been assessed for fire resistance by BRANZ (FH5551-TT) and is classified as Group 1S. KAPO Board was assessed for acoustic performance by Marshall Day Acoustic consultants.

KAPO Board is:

- Produced from natural, inorganic raw materials and the chemical reaction is irreversible which results in a chemically stable board that is hard but flexible
- Supplied in a range of thicknesses, nominally 6mm, 9mm and 12mm
- Lightweight and high bending strength, it can be easily handled and conveniently installed
- Will not rot or physically deteriorate and it is highly resistant to the effects of moisture
- Safe to work with, containing no hazardous materials and is 100% asbestos free
- Resistant to climatic conditions and moisture - tested to many cycles of soaking, freezing and heating (freeze/thaw test method)
- It has excellent workability that can be cut, drilled, sanded and worked with proper tools and machiners
- It does not sanctuary insects, mildew, mould, fungus or bacteria
- Comes with a 20 year warranty

*"WE HAVEN'T REINVENTED THE WHEEL – WE'VE SIMPLY INTRODUCED A BETTER TYRE."*

# SCOPE & LIMITATIONS

Enviro Square's KAPO Board is suitable for use as an interior lining, exterior RAB and face-sealed cladding with an exterior plaster finish.

Use of KAPO Board is subject to the limitations and conditions set out in this technical and installation manual.

**FRAMING** KAPO Board must be used in conjunction with timber framing and other components of a wall assembly that comply with NZS3604 or in place of timber framing, with lightweight steel framing that complies with NASH 3405, in all respects except as varied herein, in order to meet the Performances of the Building Code claimed in this Appraisal.

**INTERIOR FINISHES** KAPO Board has been appraised to be used as an interior lining relying on 400mm or 600mm stud centres or ceiling joist centres for framing and using either 6 or 9mm thick board. This appraisal is limited to the boards and nominated jointing systems only and excludes any finishing system, such as plastered finishes or tiling systems, which must comply with the relevant clauses of the New Zealand Building Code.

**EXTERIOR FINISHES** KAPO Board has been appraised as a Light Wall Cladding as defined in NZS3604 relying on 400mm or 600mm stud centres or soffit joist centres for framing and using either 9 or 12mm thick board.

This appraisal is limited to the boards and nominated jointing systems only and excludes any finishing system, which must comply with the relevant clauses of the New Zealand Building Code.

The KAPO Board is to be installed by trade qualified builders.

\*(Materials for nails and screws shall comply with NZS 3604:2011 depending on the severity exposure zones.

# KAPO BOARD SIZES

KAPO Board sizes. KAPO Board can be pre ordered in any dimensions, please contact us for more informations,

enquiry@envirosquare.com.

Product	Density (kg/m <sup>3</sup> )	Thickness (mm)	Length (mm)	Width (mm)	Edge
KAPO Board	1150 - 1250	6, 9 & 12	2400	1200	<ul style="list-style-type: none"> <li>• Square</li> <li>• Beveled</li> <li>• Tape</li> </ul>
			3000		

# EDGE TYPES



# ESSENTIAL COMPONENTS

To ensure compliance, the following components are required to be used in conjunction with KAPO Board:

Fixing:			
Galvanised clout (40x2.8mm) for timber frame	Fibretek screw for steal frame	Zinc plated screw 6g x 30mm for timber frame	Zinc plated screw 7g x 30mm for timber frame
Joiniting:			
Corner jointer	Joint reinforcement tape	Backing rod	lumberlock
Paper faced corner mould	cap mould 6mm for capping edge	PVC perforated corner mould 30mmx20mm for internal and external corner	PVC "H" joining strap (6mm or 9mm)
Tools			
Hand saw	Hand guillotine	Hand Drill	Table Saw blade
Collated screw gun			
Finishing			
Level ruler	Broadknife 150mm for setting joints	Trowel 200mm for installing second and finish coatings	Corner trowel for internal corner
wet wall cavity for wet area			

# ACCESSORIES

**Not supplied by Enviro Square**

The accessories describe below has been found satisfactory: Data sheet can be found at [envirosquare.com](http://envirosquare.com).

**Joints, Wholesale Insulation Ltd (Palmerston North):**

Ace Water proof jointing tape\*

**Finishing plaster paint manufactured by Nu Age, Hamilton**

KAPO Easy Mix Plaster lime finish 25KG\*

**Dulux**

For an **Interior** System, Dulux recommends the following preparation products:

- Dulux 1 Step Primer Sealer Undercoat water based
- Dulux Prepcoat Acrylic Sealer undercoat
- Dulux 1 Step Primer Sealer Undercoat oil based
- Dulux Sealer Binder oil Based

For a tradesperson finishing interior Kapo board, Dulux recommends the following preparation product to achieve a Level 5 Finish (refer to standard AS/NZS 2589 1.1997 "Gypsum lining in residential and light commercial construction – Application and finishing").

Dulux Professional Ultra 5 Surfacer, Prep & Finish

For an **Exterior** System, Dulux recommends the following preparation products:

- Dulux 1 Step Primer Sealer Undercoat water based
- Dulux 1 Step Primer Sealer Undercoat oil based
- Dulux Weathershield X 10 Low Sheen

**Top coat systems for interior walls:**

Dulux Wash & Wear Advanced

Dulux Wash & Wear Kitchen & Bathrooms

Dulux Wash & Wear Plus

**Top coat systems for exterior walls:**

Dulux Weathershield X10

**CEMIX, Auckland:**

**Rubberflex\*** highly flexible, polymer engineered and rubber modified, cement based adhesive used for most internal external wall and floor applications

**Hiflex White\*** Multi-purpose highly flexible tile adhesive

**Enviroflex\*** Premium grade highly flexible polymer engineered recycled rubber modified grey cement based water resistant adhesive

**Cemlastic\*** Latex primer & additive

**Rocket Adhesive\*** is a one part, highly flexible, polymer engineered and cement based adhesive, with a rapid setting time of 2 hrs

**Super Primer\*** Solvent free specialty primer

**Water proofing for wet area, ABEP Ltd (New Zealand)**

**Blue Barrier System\*** Blue Barrier – Flash'N Wrap RG2400

\*To achieve the best results or finishes it is recommend Enviro Square product users consult data sheets information regarding preparation and application. Additional technical information can be viewed at [www.envirosquare.com](http://www.envirosquare.com).

# VERIFICATION OF COMPLIANCE

## Methods Used for Verification

- Testing and assessment by BEAL Testing Services
- In service history - over 10 years overseas.

BEAL Testing Service's Appraisal C820 uses the in-service history provided by the manufacturer, together with the Compliance Verification Procedure – a method for demonstrating compliance with the performance requirements of the NZ Building Code - as the 'methods' for demonstrating compliance with the relevant clauses of the Building Code. [Methods suggested by the Department of Building and Housing]

Test	Method	Criteria	Result
Board density	1.03	g/cm <sup>3</sup>	CECS95:97
Bending strength (6mm Dry)	AS/NZS 2908.2	10.2 MPa	Pass
Moisture Permeability	AS/NZS 2908.2	< 0.5% w/w	Pass
Drying Shrinkage	AS/NZS 2908.2	< 0.5% l/l	Pass
Warm Water	AS/NZS 2908.2	< 0.5% w/w	Pass
Freeze-Thaw conditioning of board	Ad hoc method	No deterioration	Pass
Wet & Dry Fixing Pull-through testing	Ad hoc method	<10% reduction	Pass
Compatibility with tile adhesives (tensile adhesion test)	ASTM C297 (mod)	>0.5MPa	Pass

**NOTE:** For information about AS/NZS Test Methods, refer to [www.standards.co.nz](http://www.standards.co.nz)

## Reference Information

- AS/NZS 2908.2, Cellulose-cement products Part 2: Flat boards
- ASTM C297-94, Standard Test Method for Flatwise Tensile Strength of Standard Constructions
- NZS3604, Timber Framed Buildings
- NASH 3405:2006, Steel Framed Buildings
- Peer review report from Redco Chartered Professional Engineers
- Peer review by Marshall Day Acoustic Engineers
- Technical literature provided by the manufacturer
- BEAL Test Report TR080829d Wet & Dry Pull-through properties
- BEAL Test Report TR080919a Fixing strength properties
- BEAL Test Report TR080919b water permeability and resistance test
- BEAL Test Report TR081103 Compatibility with render properties
- BEAL Test Report TR081208a Fixing strength properties
- BEAL Test Report TR090126 Expansion properties
- BEAL Test Report TR090213c Suitability for tiling over properties



\*Data sheets available online at [www.envirosquare.com/finishing](http://www.envirosquare.com/finishing)

# VERIFICATION OF NEW ZEALAND BUILDING CODE (NZBC) PERFORMANCE CRITERIA

**Clause B1.3.3 – Structure** The KAPO Board when used as part of an exterior cladding that is designed and installed in accordance with the manufacturer's instructions must meet Performance B1 of the NZBC. In other words, the building and building elements shall withstand the combination of loads that they are likely to experience during construction or alteration and throughout their lives.

**Clause B2.3.1 (a) – Durability** The basis of BEAL's verification of the ability of the KAPO Board to meet the New Zealand Building Code performance requirement Clause 82.3.1 (a) is reference to known in service usage, being more than 15 years.

**Clause C3.4 (a) – Spread of Fire** The basis of BEAL's verification of the ability of the KAPO Board to meet the New Zealand Building Code performance requirement Clause C3.4 (a) is reference to the products Material Group Number Classification 1-S verified by BRANZ fire testing.

**Clause E2.3.2 – External Moisture** The basis of BEAL's verification of the ability of the KAPO Board to meet the New Zealand Building Code performance requirement Clause E2.3.2 was an assessment of the product using relevant sections of AS/NZS 2908.2:2000 'Cellulose-cement products Part 2: Flat boards'. The board was also evaluated in practical building situations to assess the following:

- Ease of installing the product
- Potential risks of non performance when being installed
- Any external factors that could effect the quality of the installed product
- Ease of repair or maintenance (where applicable) The impact of other building products/systems when in contact with other similar products.

**Clause F2.3.2 – Hazardous** The basis of SEAL's verification of the ability of the KAPO Board to meet the New Zealand Building Code performance requirement Clause F2.3.1 was a statement from the manufacturer about the absence of asbestos or any other hazardous materials.

**Clause G6.3.1 – Airborne and Impact Sound Walls**, The basis of SEAL's verification of the ability of the KAPO Board to contribute to meeting the New Zealand Building Code performance requirement Clause G6.3.1 was an acoustic test report and peer review. The product can contribute to this performance requirement but cannot meet this on its own.

## OTHER INVESTIGATIONS

**8.10** A peer review of the acoustic testing of the Enviro Square KAPO Board was conducted by Marshall DAY Acoustic Engineers.

**8.11** Fire testing to ASTM E136-99 and ASTM E119 was conducted by Intertek Testing Services Ltd.

**8.12** Additional fire testing was conducted in 2014 by BRANZ to NZBC verification method CNM2 Appendix A.

**8.13** The Technical Literature has been examined by BEAL and found to be satisfactory.

## STORAGE AND HANDLING

**Packaging** The KAPO Board is supplied wrapped stacked on pallets and can be stored indefinitely when kept dry and out of the weather and safe from accidental damage.

**Safe handling** Individual boards should be stacked and handled carefully to avoid damage. KAPO boards should be lifted from the pallet by sliding board sideways and carrying on long edges.

**Storage and transport** Keep dry and store in dry and covered area, if product becomes wet allow to dry before fixing is recommended. KAPO is supplied on wooden pallets with support timbers at maximum 400mm centres. Ensure product is stored on even ground.

### Storage

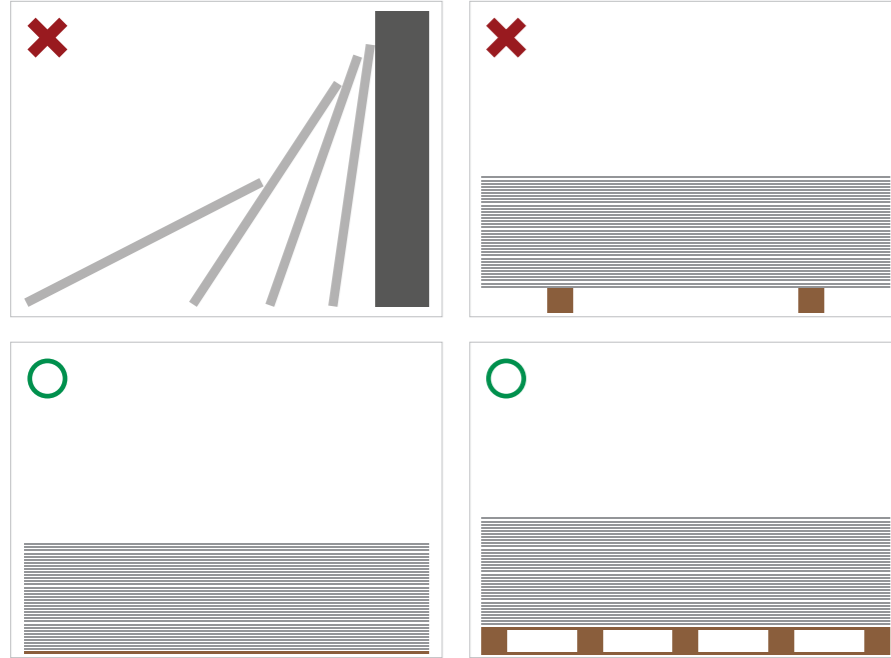

### Handling

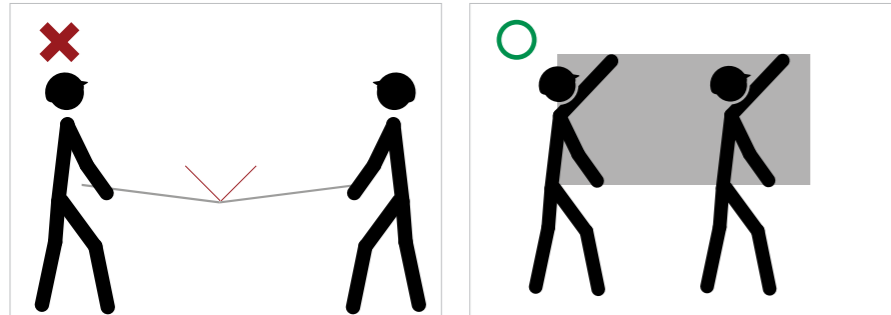

## SAFE WORKING PRACTICES

Safety is the responsibility of everyone! The following is to be used as a guide to safe work practices involving KAPO Board.

Under normal conditions of use, KAPO board presents no known direct health hazard. Construction sites can contain multiple hazards and therefore it is required that all installers follow all legal requirements when working on site. Please refer to the Ministry of Business, Innovation & Employment for OSH regulations for all relevant legislations. For more information visit [www.employment.govt.nz/er/](http://www.employment.govt.nz/er/).



## WORKING INSTRUCTION

**Power Tools** Both manual or power tool methods of fixing the nail into the sheet are acceptable using a flat head stainless steel nail. The diameter should be 2.2mm or 3.1mm with a length of 3 to 3.5 times the panel thickness. Set the power tools to 3 to 4 BAR and fine tuned to achieve required penetration. It is essential to align the sheet edge onto the center of the timber or steel structure. KAPO Boards should be installed on studs at a maximum of 600 mm.

**Cutting** can be done either longitudinally or transverse. A cut should be made on the top side of the board by means of a cutter or knife. The boards should then be pressed with both hands, cut and then snapped over a straight edge. For smooth, clean cuts use a circular saw (at least 120 carbide teeth) and set the speed above 3000 rpm.

**Sawing** Can be easily cut using a normal saw, fret saw or an electric saw. When large quantities of the boards are to be cut, the use of circular hand saw is advisable. Appropriate safety equipment should be worn.

**Drilling** Use masonry drills to countersink or drill screws. Place the boards on a solid support for a clean hole.

## PRODUCT FEATURES

**Fire rated, non Combustibility** The advantages of KAPO BOARD are light, fire resistant and achieved number classified 1-S, tested by Branz.

**Superior Moisture and Mold Resistance** KAPO will not rot, physically deteriorate, highly resistant to the effects of moisture. It absorbs moist and regains its full strength upon drying without changes to the long term performance of the board.

**Chemically stable** Board are produced from natural, inorganic raw materials and chemical reaction is irreversible which results in a chemically stable board that is hard but flexible, a strong board that maintains its strength over time.

**Tool friendly** Can be sawed and drilled.

**Safe to work** with containing no hazardous materials and 100% Asbestos free.

**Resistant to climatic conditions and moisture** Tested to many cycles of soaking, freezing, heating (freeze/ thaw test method BQI TM504 - Test Method For Accelerated Ageing Using Freeze-Thaw Cycling). The boards showed no cracking, crumbling nor disintegration for applications within normal specifications, the life span of the board is limited only by the durability of the supporting structures and the materials used in fixing.

**Easy to work and fix** KAPO Board has excellent workability that can be cut, drilled, sanded and worked with proper tools and machinery. Can be nailed or screw. Can be tiled and easily decorated.

**Highly resistant and termite attack free** Unlike plywood or wood based boards that harbors insect, mildews, molds, fungus and bacteria. KAPO BOARD maintains the beauty, cleanliness and healthy surroundings in your particular application.

**20 Year warranty** you can rely on, see page 28 for more details.





## INSTALLATION

## FRAMING

**Framing** KAPO Board must be used in conjunction with timber framing and other components of a wall assembly that comply with NZS3604 or in place of timber framing, with lightweight steel framing that complies with NASH 3405, in all respects except as varied herein, in order to meet the Performances of the Building Code described in this Technical Manual.

**Fixing to timber framing** shall be by way of 40mm galvanised clouts (complying with NZS 3604) at 200mm centres. Fixing to steel framing shall be by way of 20mm Fibre Tek screws. It is essential that the fixings are not closer than 12mm from the edge of the sheets and not over-tightened. All details of the construction and installation of the KAPO Board as an interior or exterior lining, must comply with NZS3604 except where varied by this Technical Manual. Joints between boards are to be filled using Enviro Square approved jointing product, which may be applied by machine or by hand tool to a smooth finish. Where an external render system is to be applied, the joints may be sealed in both the vertical and horizontal directions by way of Ace Water proof jointing tape. There is a Technical Manual describing the correct method of installation of this tape.

## TYPICAL WALL LAYOUT (UNTILED)

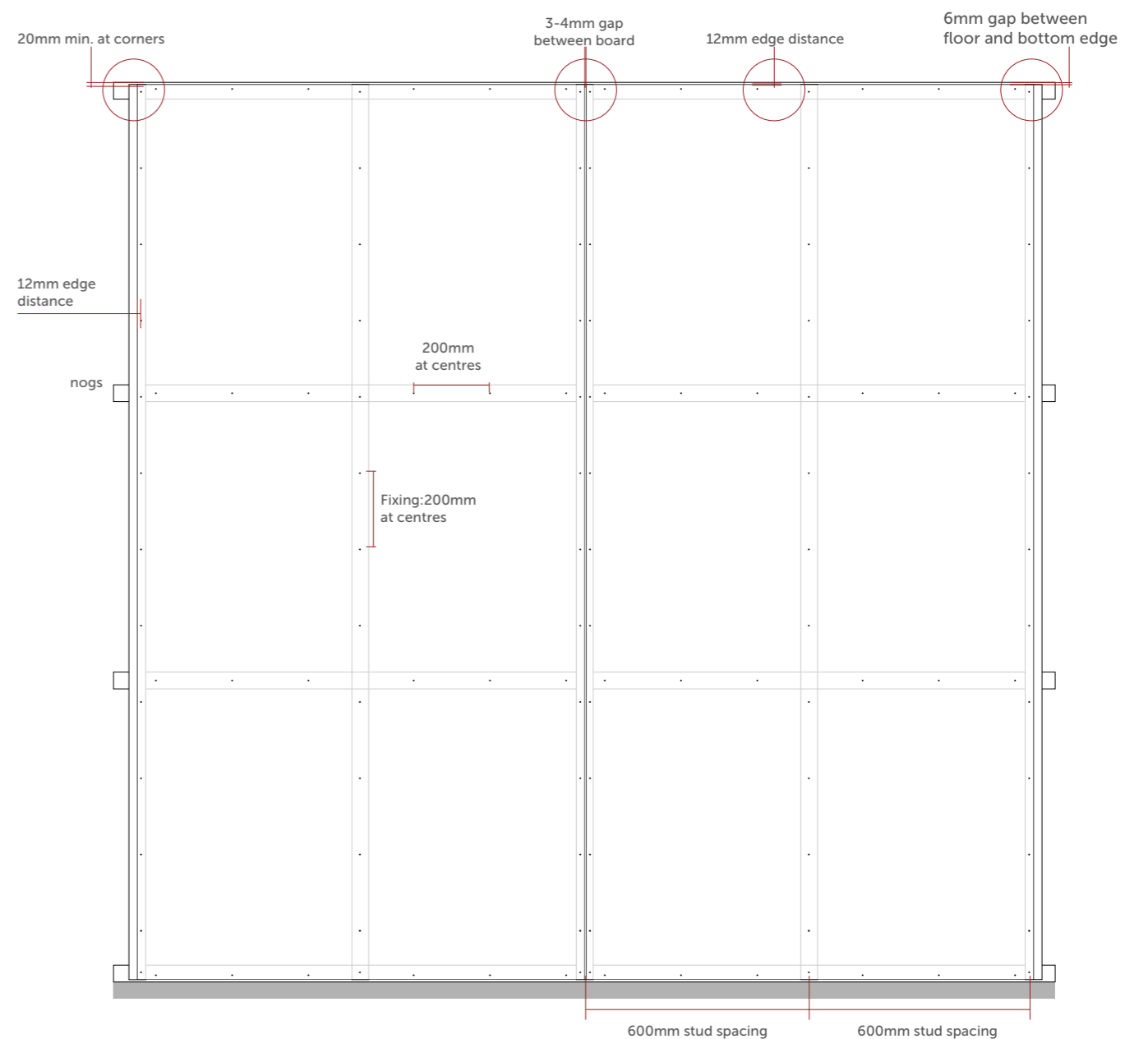

# TYPICAL WALL LAYOUT (TILED)

\*(Materials for nails and screws shall comply with NZS 3604:2011 depending on the severity exposure zones.)

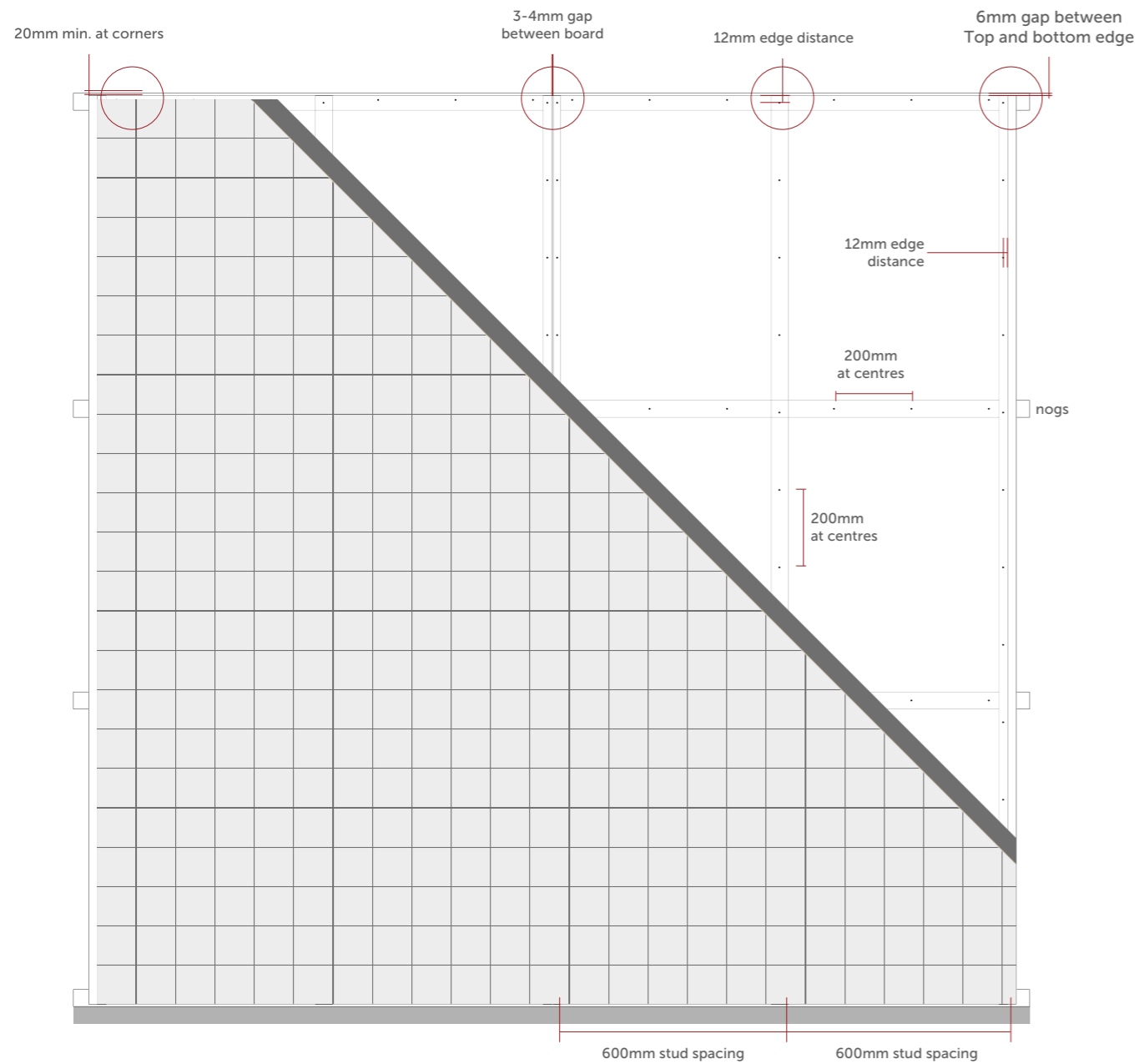

# FIXINGS

**Galvanised steel channel sections**, 30mm x 67mm x 30mm x 0.8mm thick, shall be fixed on the floor and ceiling, using 22mm anchor fixings, set at 600mm centers and inset 305mm from the vertical edges of the partition.

**Galvanised steel studding**, 35mm x 65mm x 35mm x 0.8mm thick, shall be installed vertically in the top and bottom track at 2400mm interval, allowing a 15mm gap at the top of each stud for expansion. The stud forming the restrained edge of the partition, shall be fixed to frame using 22mm anchor fixings at 1,220mm centers inset 600mm and 610mm from the top and bottom of the partition fixed (unstrained edge) as required by the standard.

# FIXING ON STEEL FRAMING

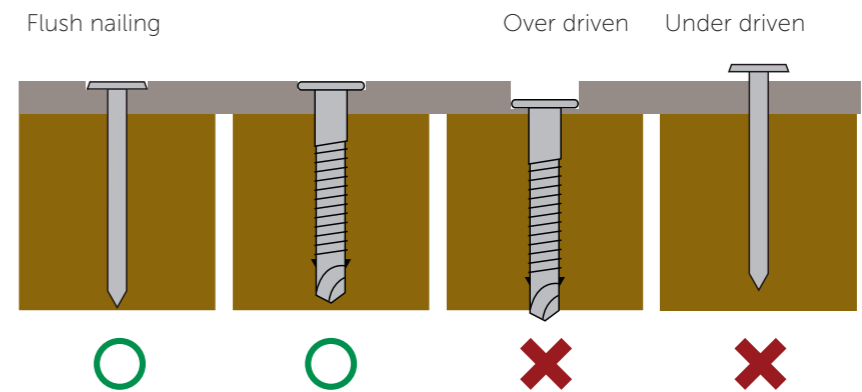
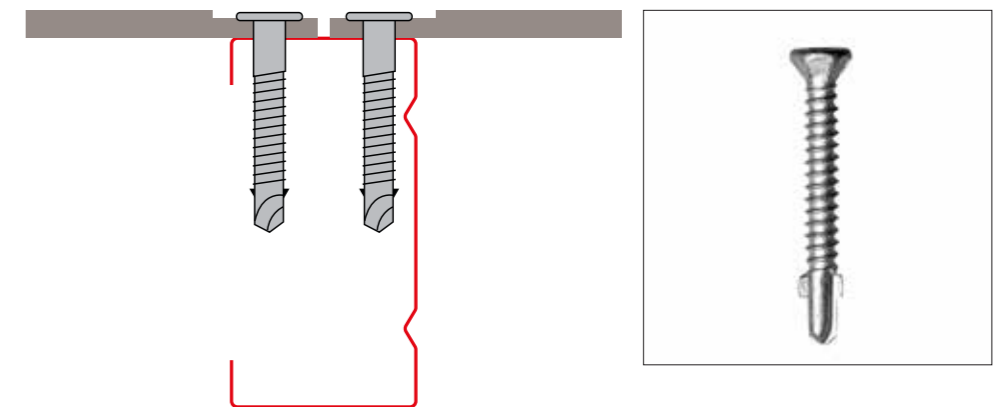

# STRUCTURAL / BRACING WALL LAYOUT

No nogs	Bracing Unit	Length	thickness	walls
BU wind	79	1200	6mm	1200 x 2400
BU earthquake	68			

tested by Scion research.

\*(Materials for nails and screws shall comply with NZS 3604:2011 depending on the severity exposure zones.

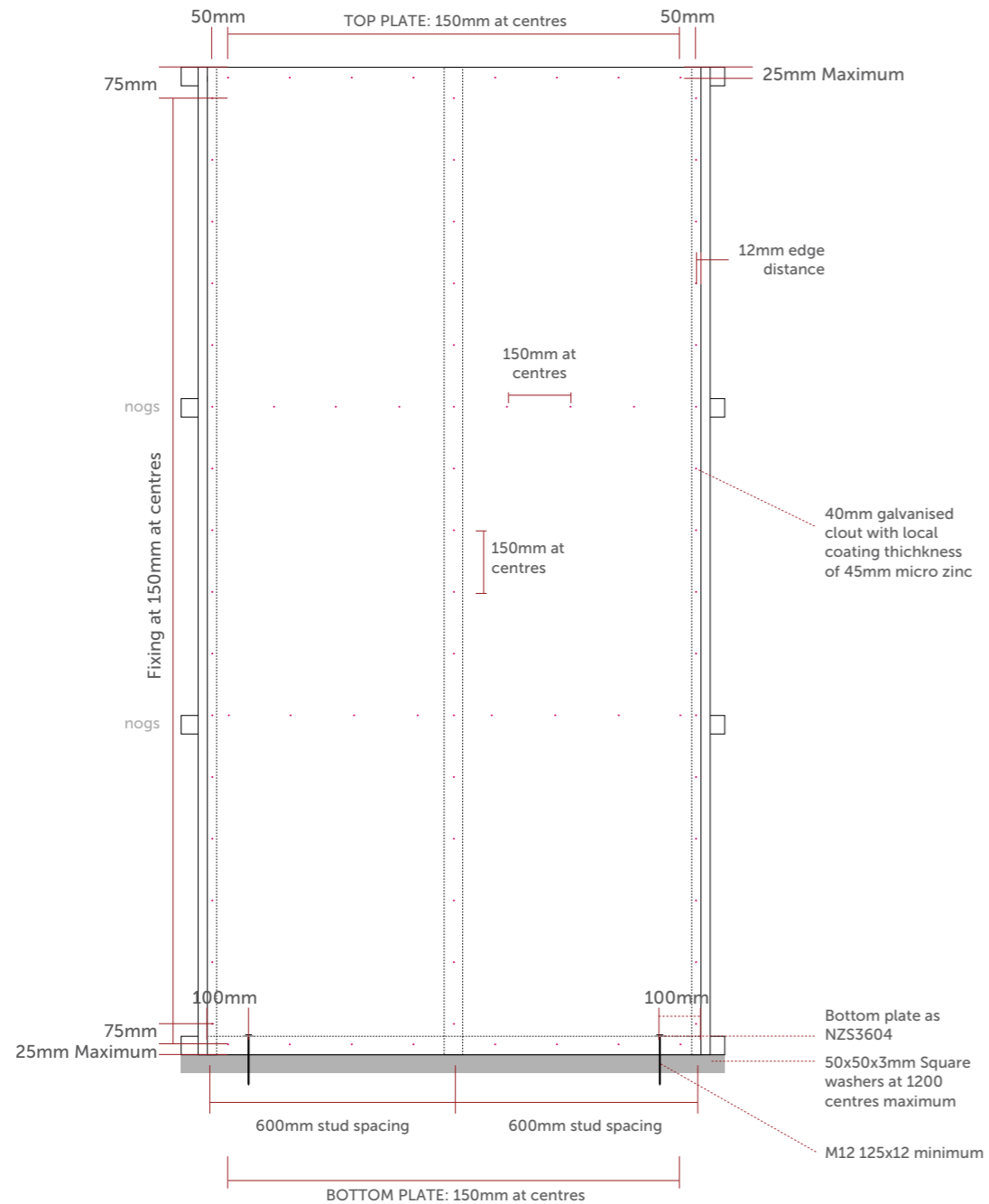

# 1. JOINTING INTERNAL WALL

**Sheet Joints** KAPO Boards are suitable for mounting to both timber and metal framing. Studs are recommended at a minimum of 400mm centres. A sufficient gap between the joint 2 boards is required, nominally 4 mm.

**Support Structures** KAPO Board sheets shall be supported by framing members spaced at no more than 600mm centres for both 6mm and 9mm thickness.

**Gaps** at all board joints, plus screw fixings at joint and intermediate position, shall be in filled and covered with fibrous adhesive, applied to give a board covering approximately 0.5mm thick in the immediate vicinity of the joints and fixings.

## TAPE JOINT

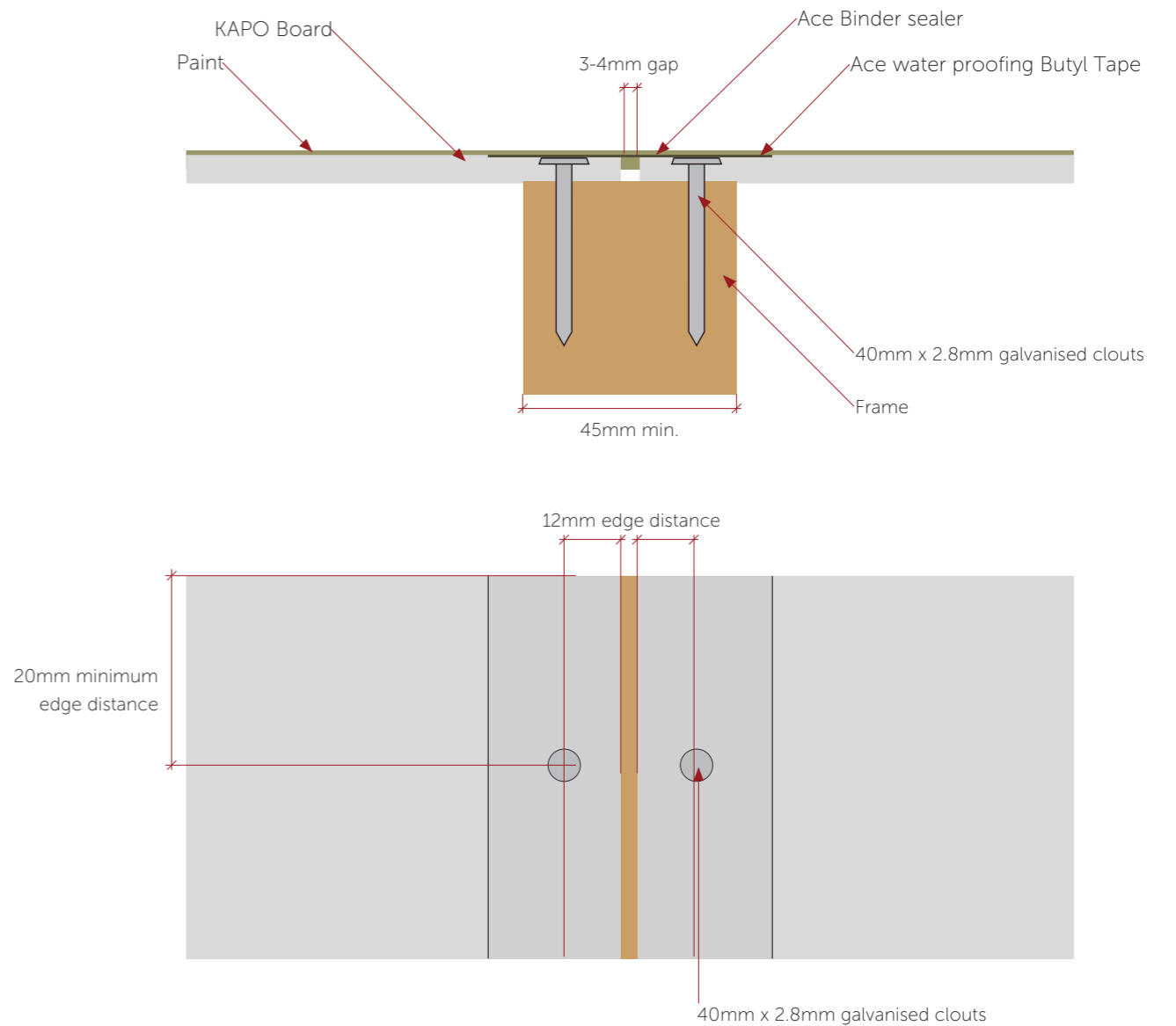



# 2. TYPICAL LAYOUT OF STEEL FRAME

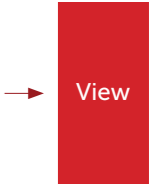

## BUTT JOINT DRY AREA

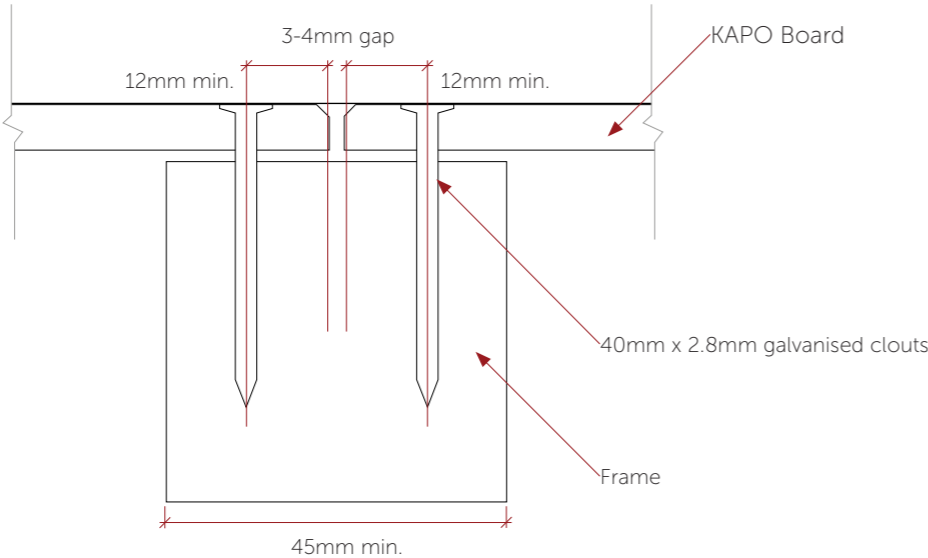

## BUTT JOINT WET AREA

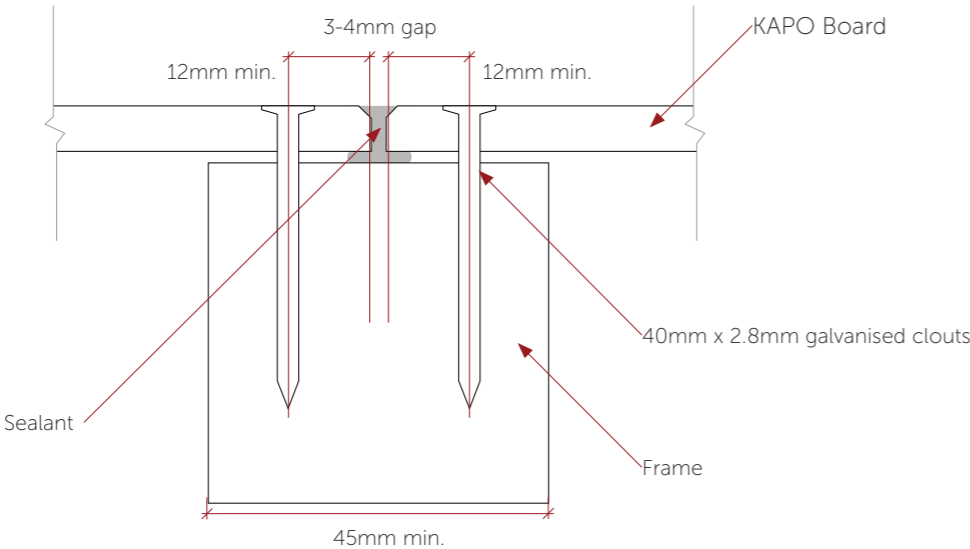

## PVC JOINT

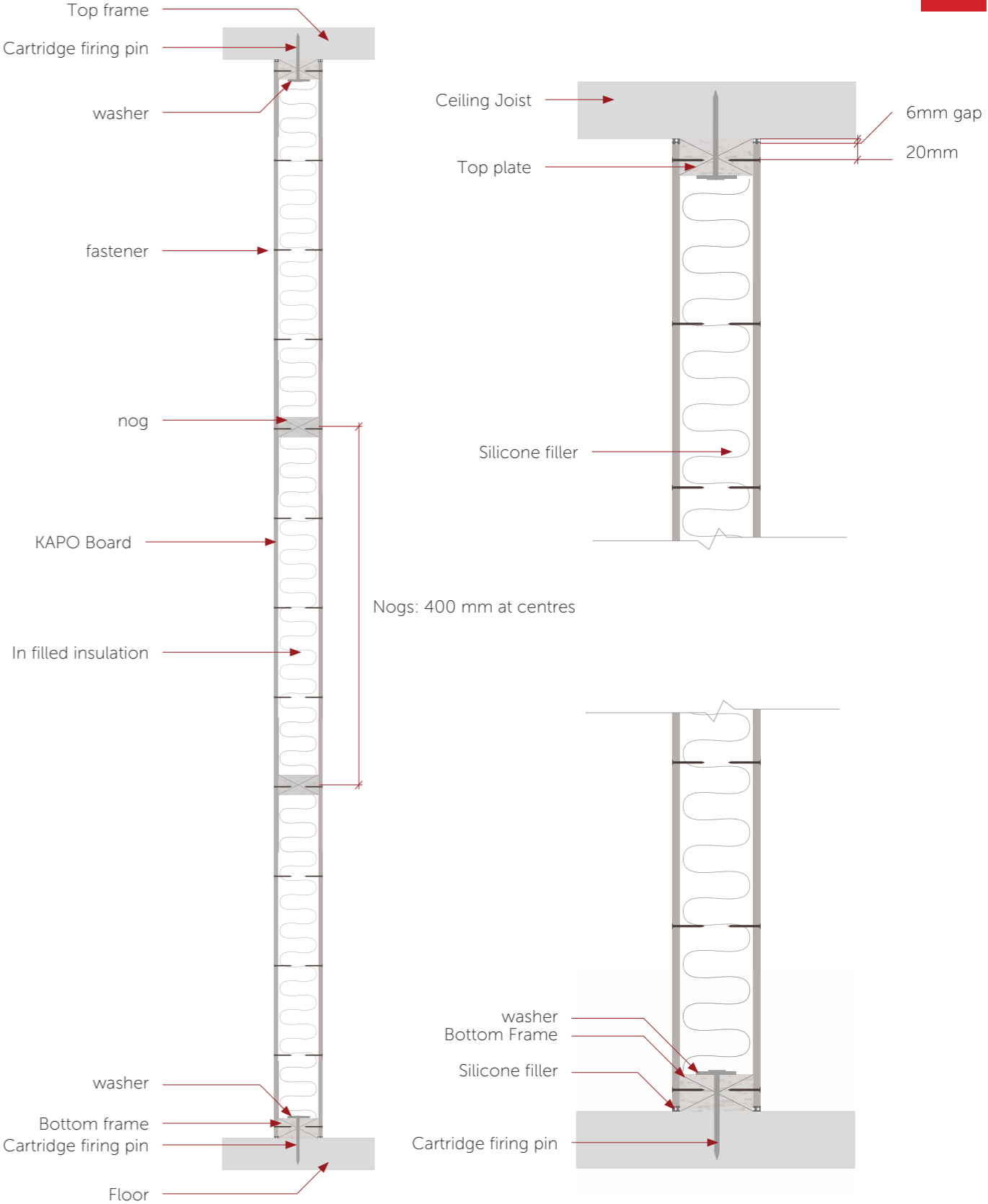
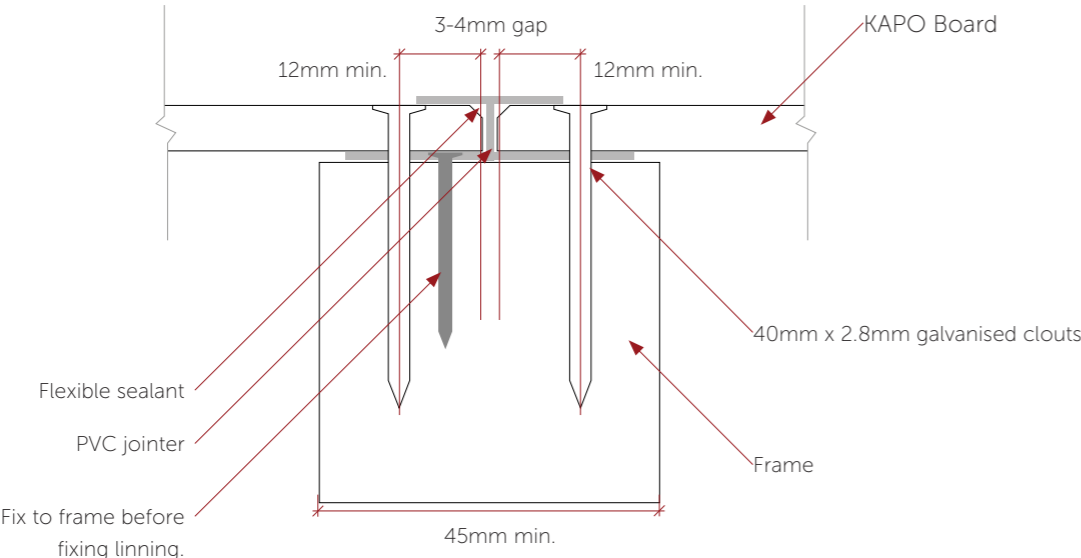

Interior Finishes KAPO Board has been appraised for use as an interior lining relying on 400mm or 600mm stud centres or ceiling joist centres for framing and using either 6 or 9mm thick board. This appraisal is limited to the boards and nominated jointing systems only and excludes any finishing system, such as plastered finishes or tiling systems, which must comply with the relevant clauses of the New Zealand Building Code.

\*(Materials for nails and screws shall comply with NZS 3604:2011 depending on the severity exposure zones.

View

### 3. PARTITION & EXISTING FLOOR

View

#### (CROSS SECTION HORIZONTAL VIEW)

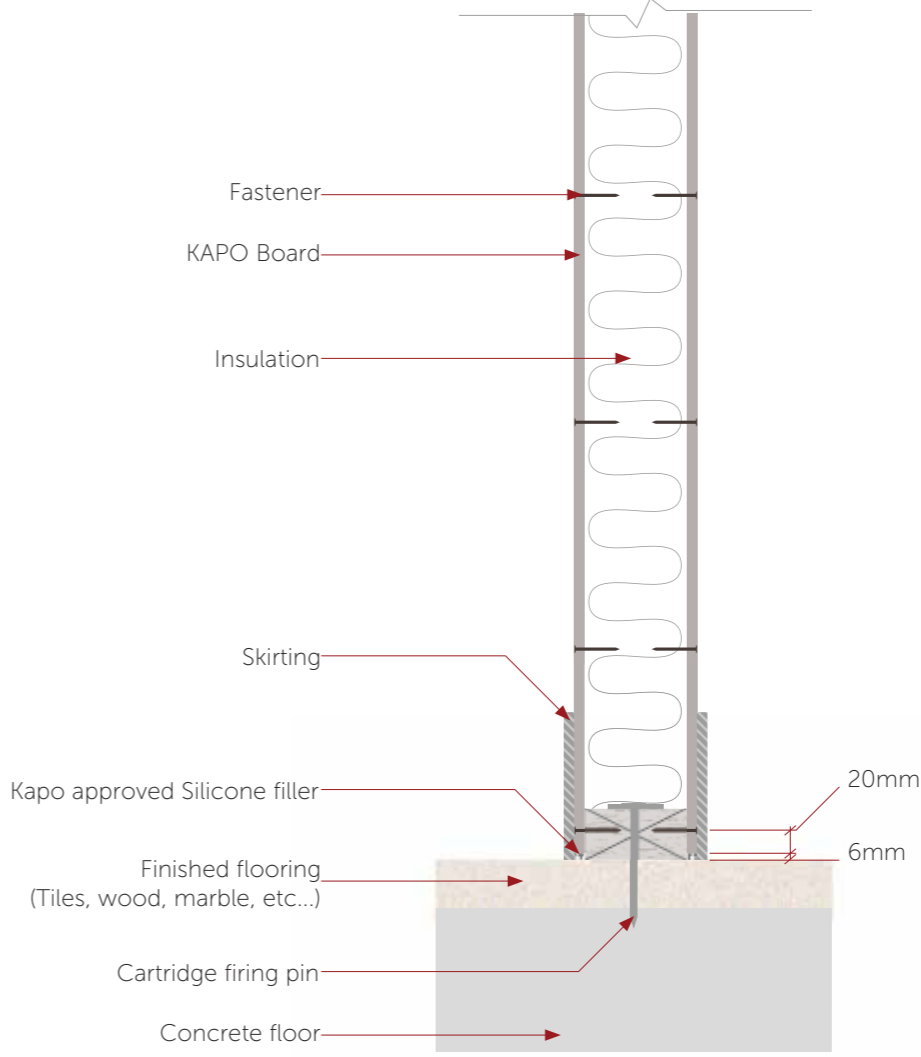
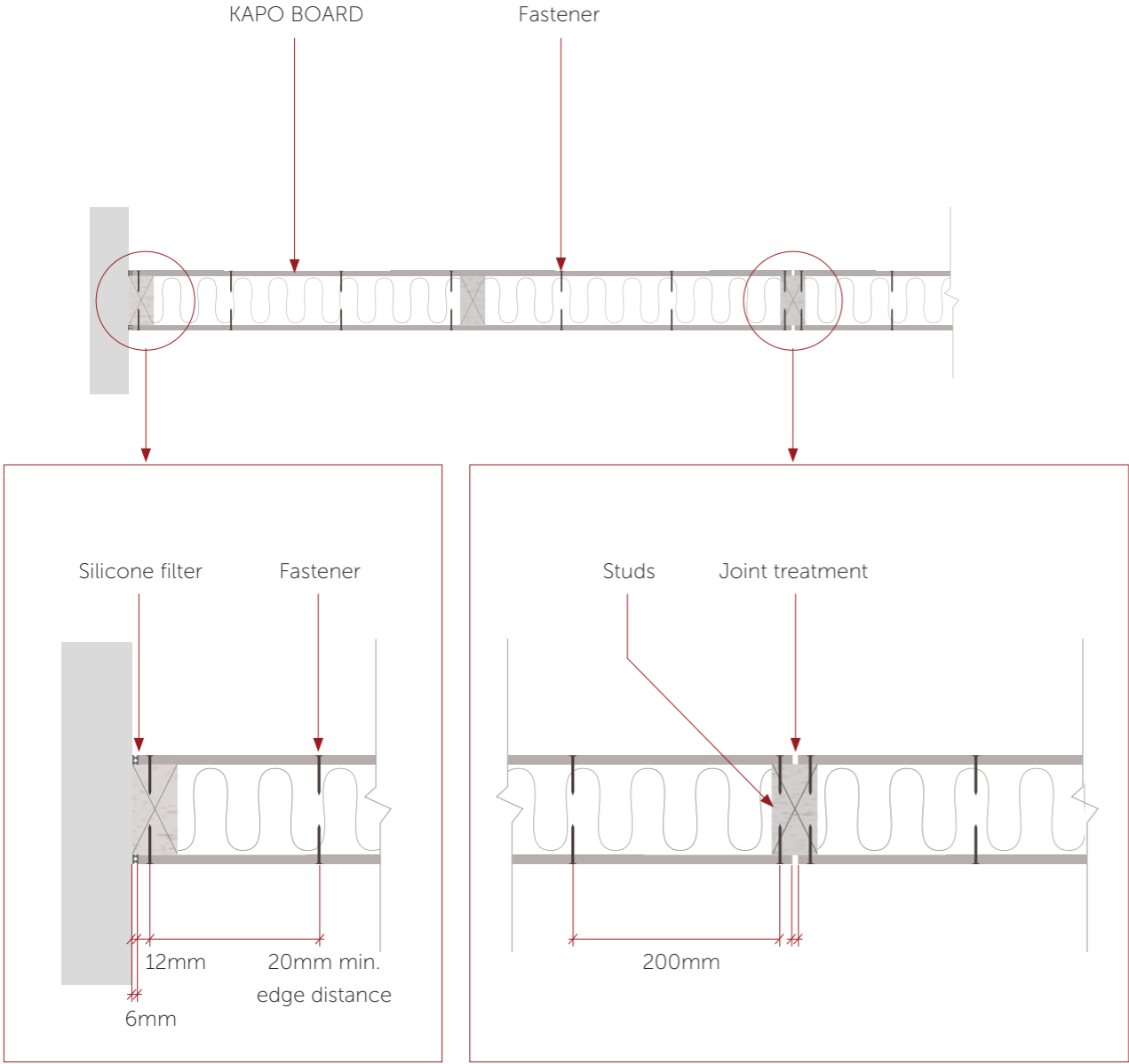

Interior Finishes KAPO Board has been appraised for use as an interior lining relying on 400mm or 600mm stud centres or ceiling joist centres for framing and using either 6 or 9mm thick board. This appraisal is limited to the boards and nominated jointing systems only and excludes any finishing system, such as plastered finishes or tiling systems, which must comply with the relevant clauses of the New Zealand Building Code.

\*(Materials for nails and screws shall comply with NZS 3604:2011 depending on the severity exposure zones.

\*(Materials for nails and screws shall comply with NZS 3604:2011 depending on the severity exposure zones.

## 4. CONCRETE CEILING PARTITION WALL + SUSPENSION CEILING

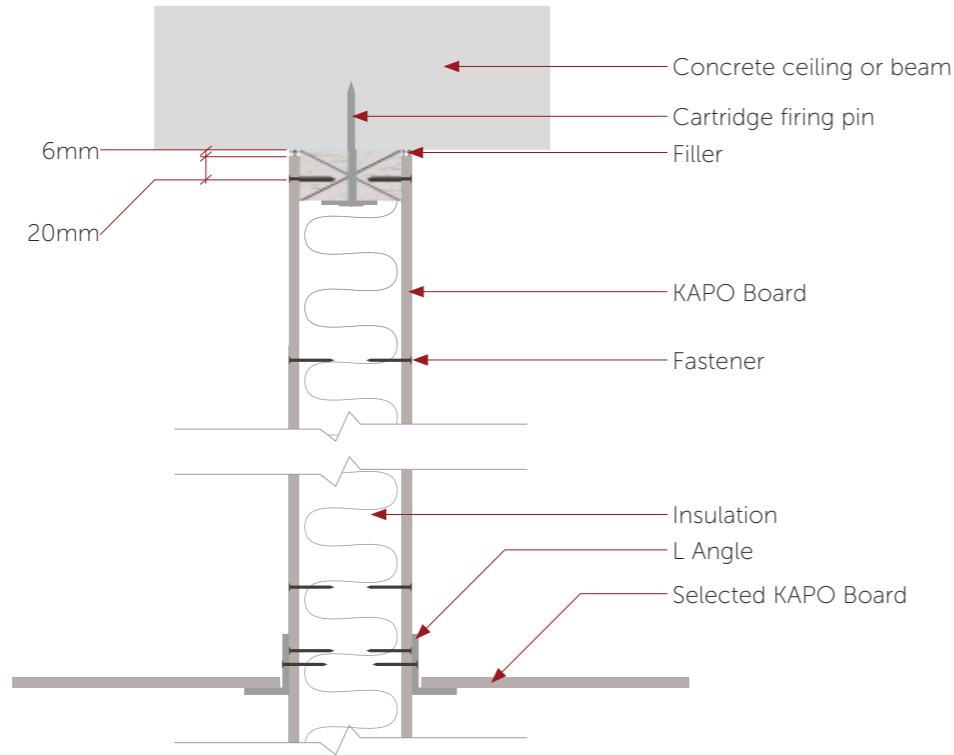

## 5. L-CORNER JOINT CROSS SECTION

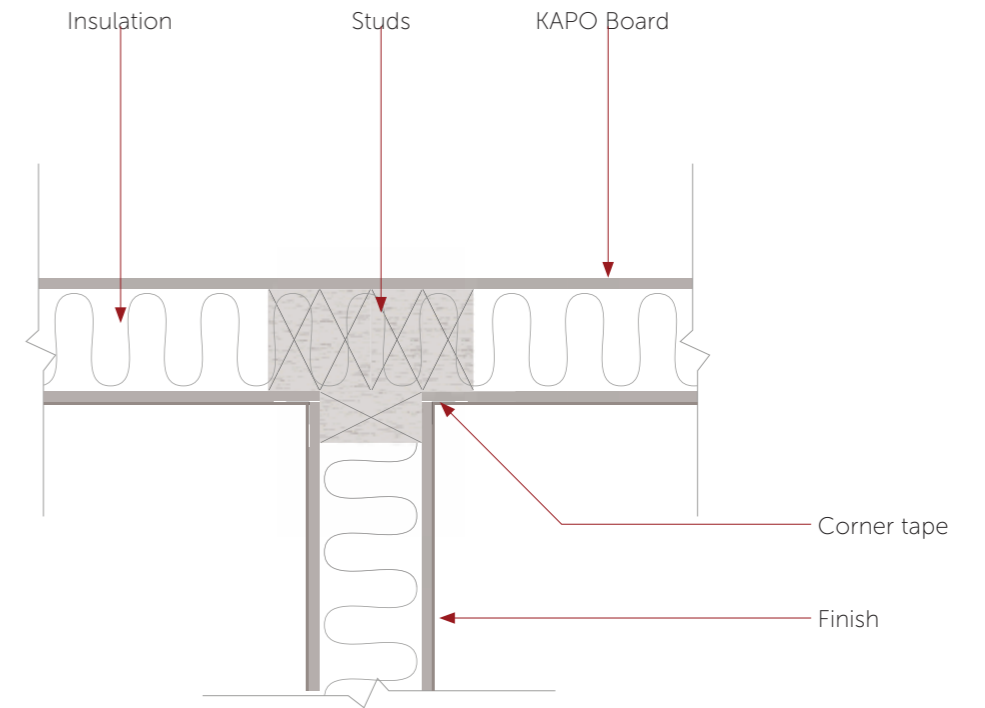

\*(Materials for nails and screws shall comply with NZS 3604:2011 depending on the severity exposure zones.

\*(Materials for nails and screws shall comply with NZS 3604:2011 depending on the severity exposure zones.

## 6. "T" SECTION PARTITION

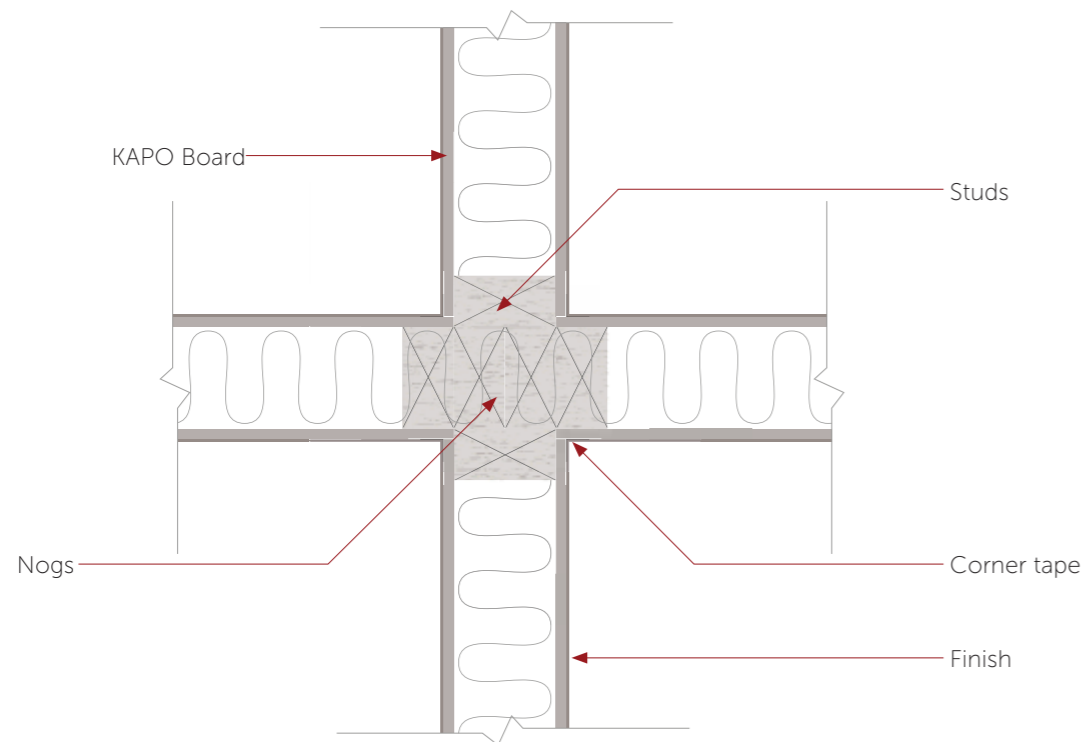

## 7. TYPICAL CEILING LAYOUT

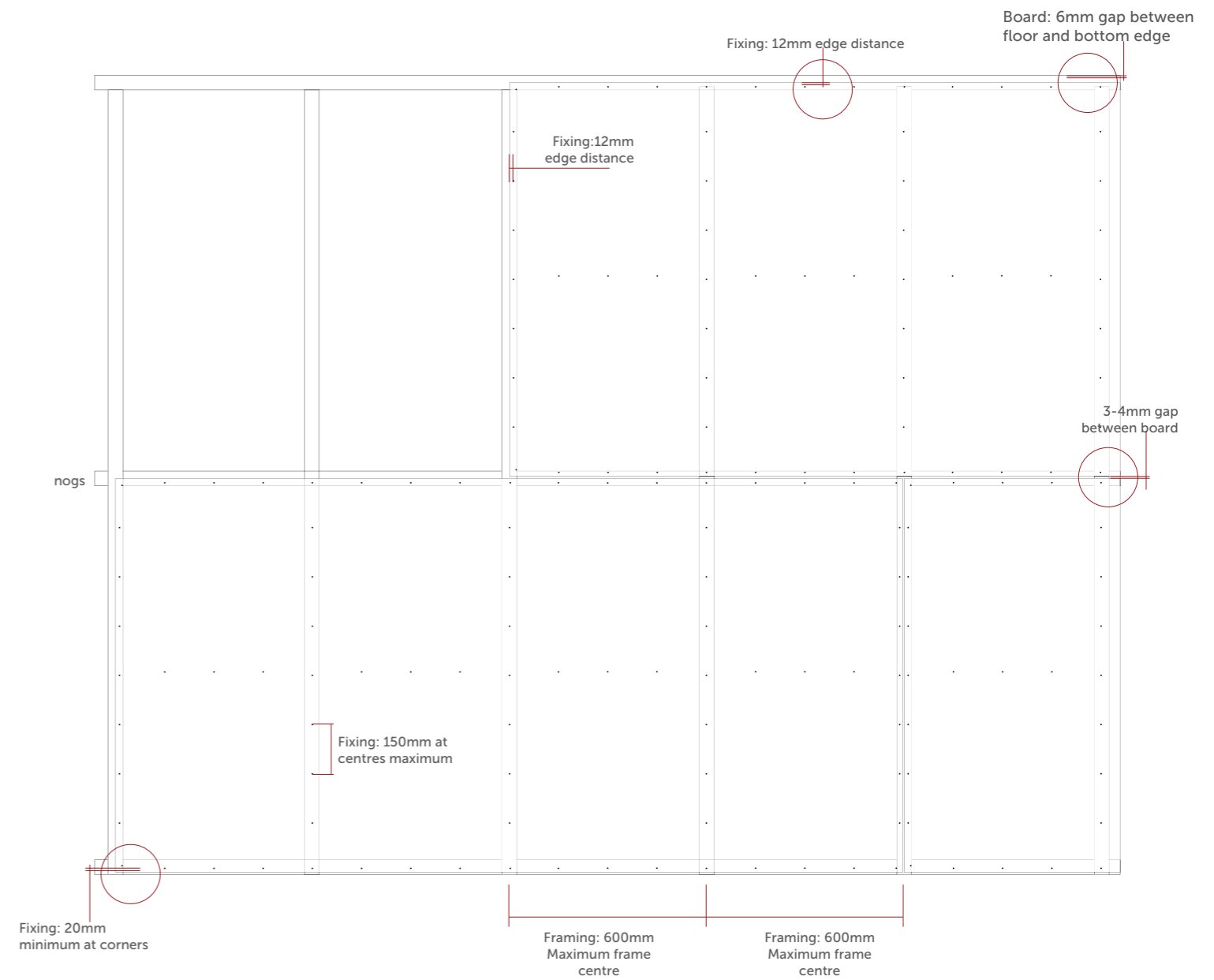

\*(Materials for nails and screws shall comply with NZS 3604:2011 depending on the severity exposure zones.



## 1. SET RECESSED EDGE JOINTS

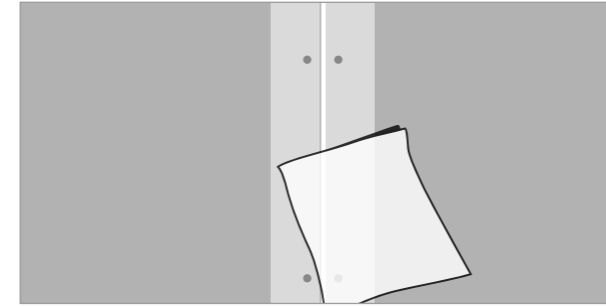

Step 1 – Preparation

Ensure that the recesses are clean and free of dust and contaminants. Sheet edges must be sealed prior to stopping with Multiplast Resin water proofing admixture or other similar products. If working conditions are hot and dry, dampen the area around the joint prior to working.



Step 2 – First coat

Apply Base Coat to fill the recess with a 150mm broad knife.

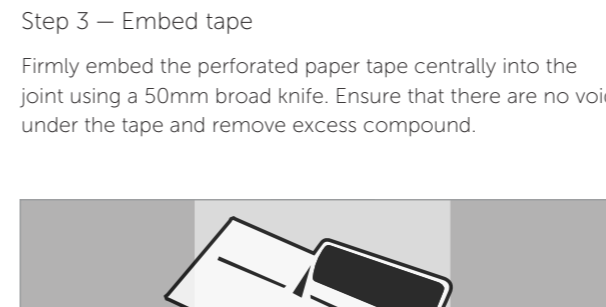

Step 3 – Embed tape

Firmly embed the perforated paper tape centrally into the joint using a 50mm broad knife. Ensure that there are no voids under the tape and remove excess compound.

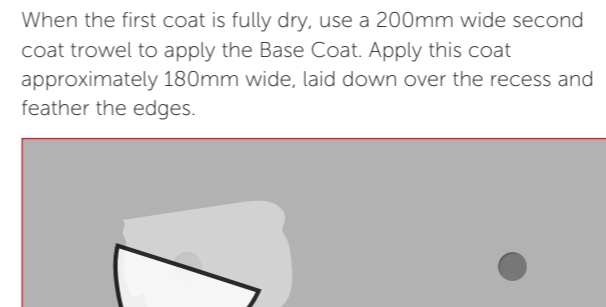

Step 4 – Thin layer

Immediately fill joint covering tape with a layer of Base Coat applied with a 150mm broad knife.

Note: Steps 5, 6 and 7 are only required for paint and wall paper finishes up to a level 4 finish. Refer Table 9 for level 5 finish.

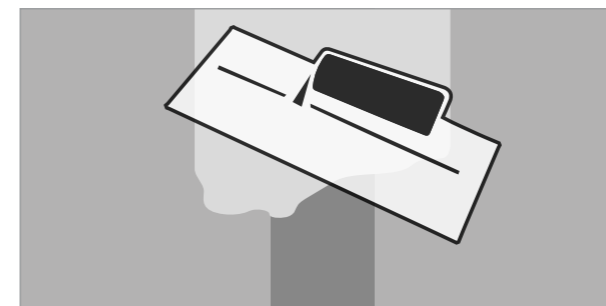

Step 5 – Second coat (untiled walls only)

When the first coat is fully dry, use a 200mm wide second coat trowel to apply the Base Coat. Apply this coat approximately 180mm wide, laid down over the recess and feather the edges.

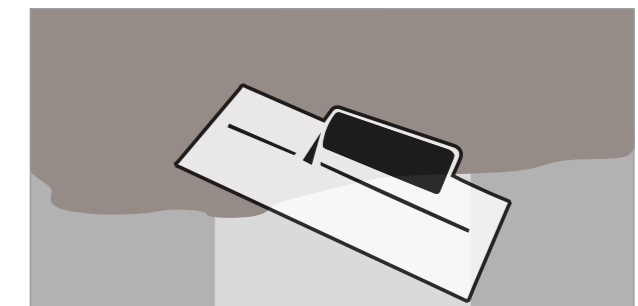

Step 6 – Finishing coat (untiled walls only)

Ensure the second coat is fully dry. Using a finishing trowel, apply a Top Coat 280mm wide centrally over the joint and feather out the edges. Allow to dry fully before sanding.



Step 7 – Fastener heads (untiled walls only)

Apply a finishing coat to fastener heads, feathering out the edges. Allow to fully dry before sanding.



## 2. SET SQUARE EDGE JOINTS

As an alternative to setting the recessed edge joints, square edge KAPO Board can also be jointed and stopped on stud as shown below. This detail will achieve a level 3 finish.

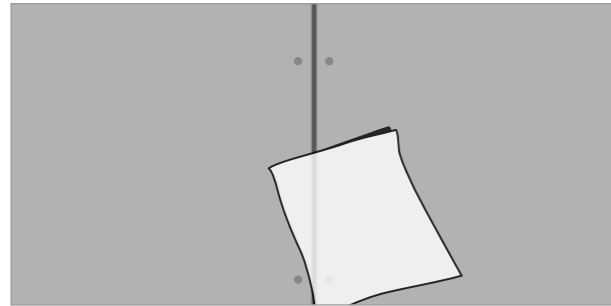

Step 1 — Preparation

When jointing un-recessed sheet joint, ensure that sheet edges are clean and free of dust and contaminants. Sheet edges must be sealed prior to stopping with Multiplast Resin water proofing admixture or other similar products. If working conditions are hot and dry, dampen the area around the joint prior to working.



Step 3 — Embed tape

Firmly embed the perforated paper tape centrally using a 50mm broadknife. Ensure that there are no voids under the tape and remove excess compound.

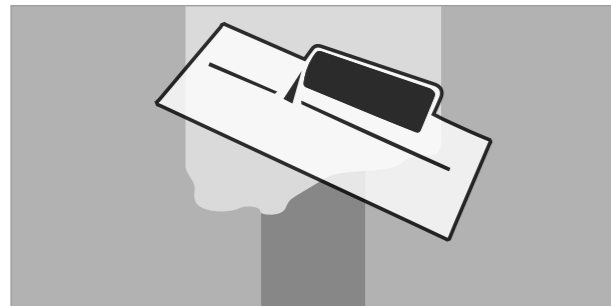

Step 5 — Second coat (untiled walls only)

When the first coat is fully dry, use a 200mm wide second coat trowel to apply the Base Coat. Apply this coat approximately 300mm wide.

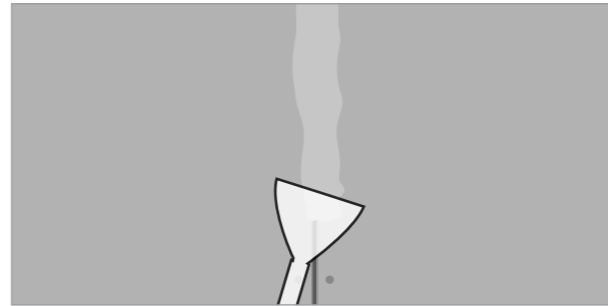

Step 2 — First coat

Apply Base Coat centrally over butt joint to 200mm wide with a 150mm broadknife.

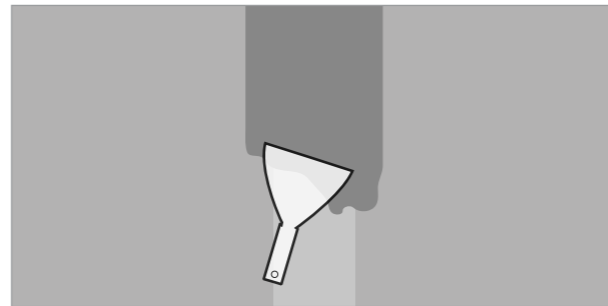

Step 4 — Thin layer

Immediately cover tape with a thin layer of Base Coat applied with a 150mm broadknife.

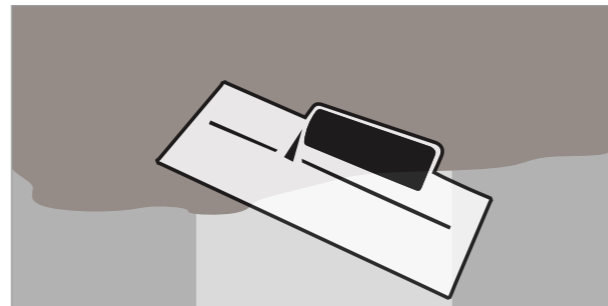

Step 6 — Finishing coat (untiled walls only)

Ensure the second coat is fully dry. Using a finishing trowel, apply a Top Coat 500mm wide centrally over the joint and feather out the edges. Allow to fully dry before sanding.

## 3. INTERNAL CORNERS

The internal corners can be formed as per one of the following two methods:

Method A:

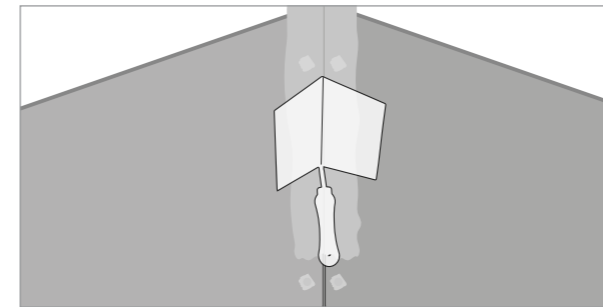

Step 1. Apply Base Coat to both sides of the corner using a 70mm broad knife. Fold the perforated paper tape to form a corner and embed it into the corner using 50mm wide corner trowel.

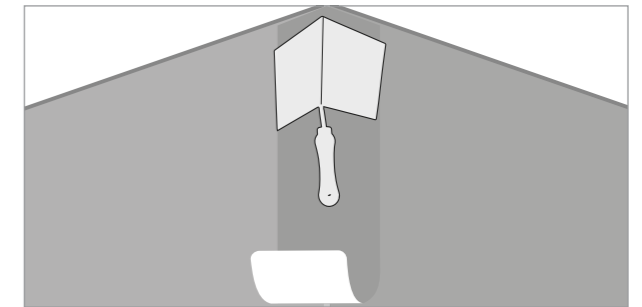

Step 2. Cover the paper tape with Base Coat using a 100mm corner trowel. Allow the base coat to dry. This will normally take up to 24 hours depending upon the temperatures and humidity conditions.

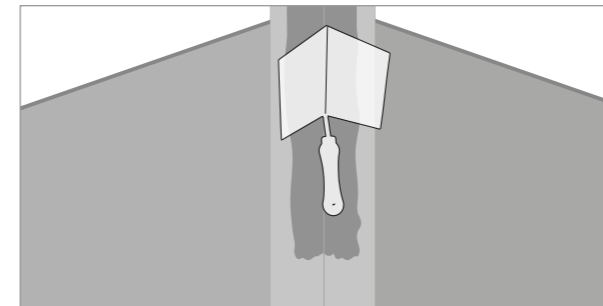

Step 3. Once the base coat has dried then apply a thin finishing coat over it with a corner trowel and smooth it out. Allow the compounds to fully dry before sanding.

Note: Step 3 is only required for untiled walls.

Method B:

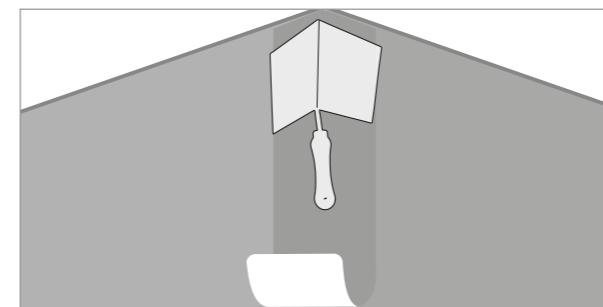

Embed and fix a paper faced rigid spine corner mould (Goldline) in the corner and then stop over it using a Base Coat. Follow steps 2 and 3 mentioned above to finish the corner joint.

## 4. EXTERNAL CORNERS

Setting of external corners is required for untiled applications only as follows:

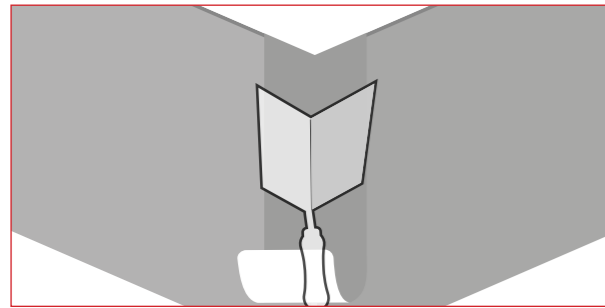

- Fit a perforated corner angle or a paper faced rigid spine corner mould (Goldline) over the external corner and ensure straightness before fixing with Galvanised clouts nails at 200mm centres.

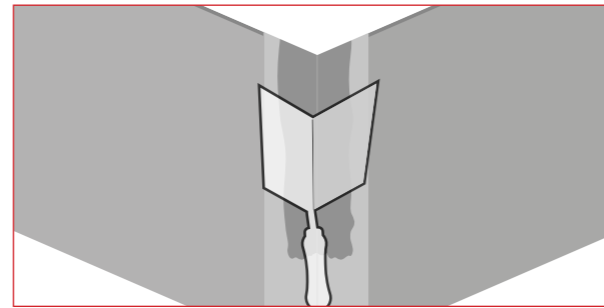

- Apply Base Coat to both sides of the corner angle to a width of using a corner trowel/broad knife. Allow to dry before applying a second coat.

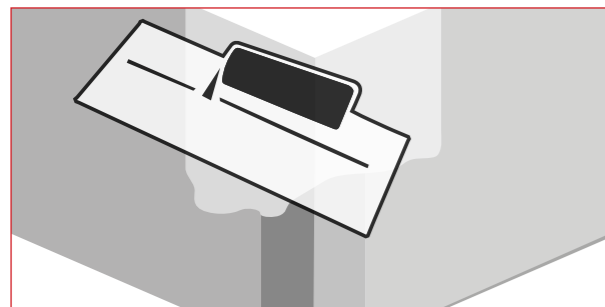

- Using a straight trowel, build up the edges to 250mm from the corner. Allow to dry. When dry, use the straight trowel to apply a thin finishing coat, to both sides of the corner angle, feathering out the edges.

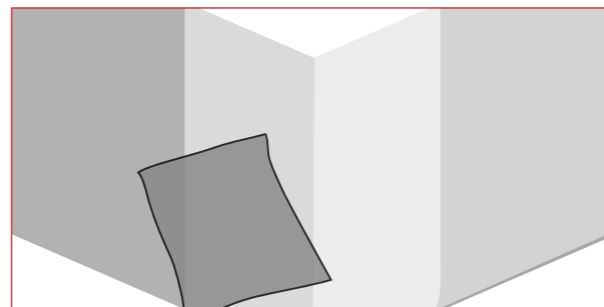

- Allow to fully dry before sanding.

## 5. TYPICAL FINISHING FOR INTERIOR WALL

1: Pre-finished Lime Plaster

KAPO ready-mix 450 (manufactured in New Zealand)

Mixing

Sprinkle KAPO Ready-mix Lime Finish 450 into the required amount of water and allow to soak for up to 30 minutes prior to use. Drill well, ensuring no un-mixed material or lumps are present. It is very important that all tools, mixing equipment and buckets are totally clean and that during mixing or application no sand particles are introduced into the KAPO Ready-mix Lime Finish 450 which may affect the performance of the material.

Over coating

KAPO Ready-mix Lime Finish 450 Plaster products may be over coated if required using a suitable 'breathable' paint system or clear coating. We would suggest to add a 5mm square alkali resistant mesh about half way through the coating, this will strengthen and also aid cracking.

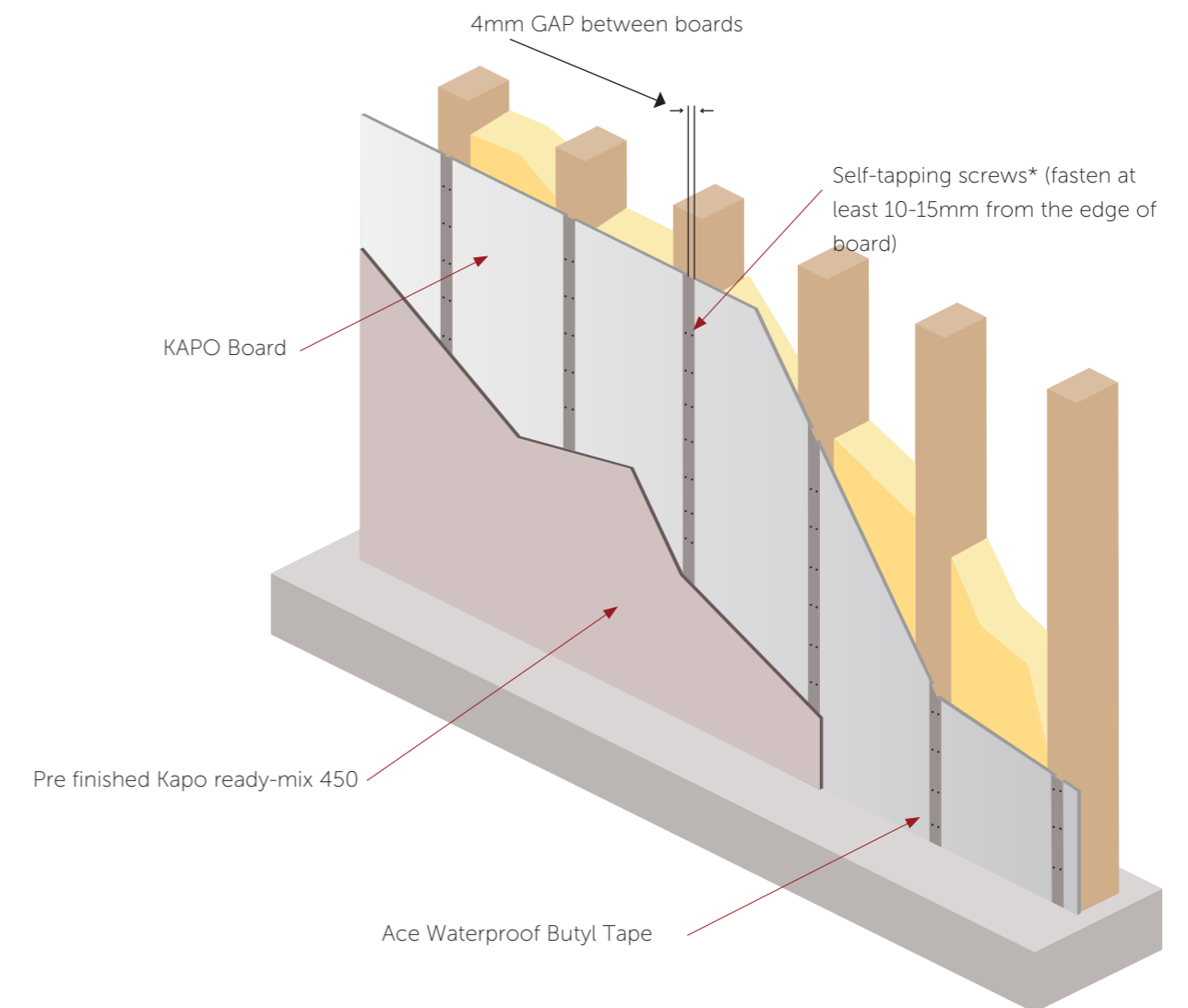

**IMPORTANT:** Do not re-use mixed material for following coat. Re-Mix fresh material. Over-trowelling of the KAPO Ready-mix Lime Finish 450 may result in bubbles appearing under the surface. If bubbles appear refrain from additional trowelling of the material, under normal circumstances the bubbles will disappear as the material cures.

Various effects can be achieved using this material and hand applied techniques, consult EZY MIX staff for range of effect options.

\*(Materials for nails and screws shall comply with NZS 3604:2011 depending on the severity exposure zones.

## 6. INTERIOR WALL WITH MESH FOR HIGH WIND ZONE

2: Pre-finished Lime Plaster with mesh for better strength

Kapo ready-mix 450 (manufactured in New Zealand)

Mixing

Sprinkle KAPO Ready-mix Lime Finish 450 into the required amount of water and allow to soak for up to 30 minutes prior to use. Drill well, ensuring no un-mixed material or lumps are present. It is very important that all tools, mixing equipment and buckets are totally clean and that during mixing or application no sand particles are introduced into the KAPO Ready-mix Lime Finish 450 which may affect the performance of the material.

Over coating

KAPO Ready-mix Lime Finish 450 Plaster products may be over coated if required using a suitable 'breathable' paint system or clear coating. We would suggest to add a 5mm square alkali resistant mesh about half way through the coating, this will strengthen and also aid cracking.

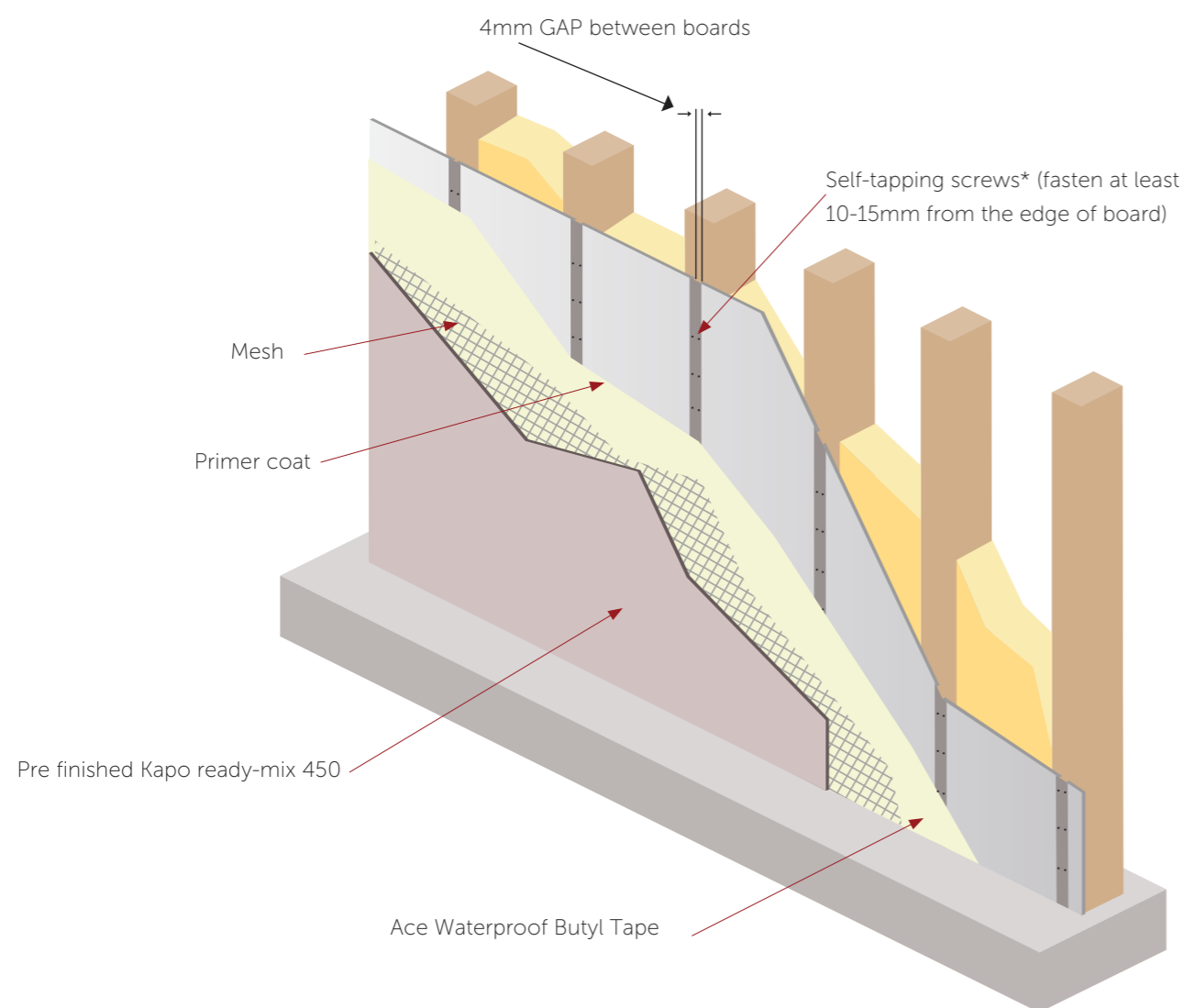

**IMPORTANT:** Do not re-use mixed material for following coat. Re-Mix fresh material. Over-trowelling of the KAPO Ready-mix Lime Finish 450 may result in bubbles appearing under the surface. If bubbles appear refrain from additional trowelling of the material, under normal circumstances the bubbles will disappear as the material cures.

Various effects can be achieved using this material and hand applied techniques, consult EZYMIX staff for range of effect options.

\*(Materials for nails and screws shall comply with NZS 3604:2011 depending on the severity exposure zones.

## DULUX FINISH



150 Hutt Park Road  
Gracefield, Lower Hutt  
New Zealand

PO Box 30-749  
Lower Hutt

Tel +64 4 576 6400  
0800 4 DULUX (38589)  
Orders 0800 800 424

Fax  
Tech. Services +64 4 576 6425  
Orders/Enquiries 0800 801 424

**Dulux New Zealand**  
*Worth doing, worth Dulux*

### Coating Kapo Board with Dulux

Technical Services Laboratory – Lower Hutt

Date: March, 2015

Kapo Board is a board manufactured from non-toxic minerals incorporating a woven mesh, which exhibits excellent fire, sound, moisture and mould resistant properties. It is used extensively overseas as a wall-papered lining alternative to plaster-based boards for interior use.

An adhesion study (refer to report no. R/2015/05) was carried out using Dulux water borne and solvent borne products on Kapo Board™. Samples were supplied by Soon from Enviro Square Ltd.

Surface preparation: Fill all imperfections with a suitable filler and sand smooth. For maximum adhesion, ensure all surfaces are dust free by wiping down with a damp cloth.

For an Interior System, Dulux recommends the following preparation products:

- Dulux 1 Step Primer Sealer Undercoat water based
- Dulux Prepcoat Acrylic Sealer undercoat
- Dulux 1 Step Primer Sealer Undercoat oil based
- Dulux Sealer Binder oil Based

For a tradesperson finishing interior Kapo board, Dulux recommends the following preparation product to achieve a Level 5 Finish (refer to standard AS/NZS 2589 1.1997 "Gypsum lining in residential and light commercial construction – Application and finishing").

- Dulux Professional Ultra 5 Surfacer, Prep & Finish

For an Exterior System, Dulux recommends the following preparation products:

- Dulux 1 Step Primer Sealer Undercoat water based
- Dulux 1 Step Primer Sealer Undercoat oil based
- Dulux Weathershield X 10 Low Sheen

Top coat systems for interior walls:

- Dulux Wash & Wear Advanced
- Dulux Wash & Wear Kitchen & Bathrooms
- Dulux Wash & Wear Plus

Top coat systems for exterior walls:

- Dulux Weathershield X10

To achieve the best finish it is also recommended that Dulux product users consult packaging information regarding preparation and application. Additional technical information can be viewed at [www.duspec.co.nz](http://www.duspec.co.nz) and also from the Dulux website [www.dulux.co.nz](http://www.dulux.co.nz)

*Note: - No exterior durability testing has been completed using the recommended systems; exposure testing is underway and panels will be reviewed 6 monthly.*

**Disclaimer:**

The data provided in this report is correct at the time of reporting; however it is the responsibility of those using this information to check that it is current prior to specifying or using any of these coating/product systems.

This report is based on adhesion testing only and Dulux takes no responsibility for the adhesion testing of untested products including competitor products and systems.

Dulux New Zealand consisting of Dulux Decorative, British Paints, Intergrain, Feast Watson, Cabot's.  
A consumer brand of DuluxGroup



## PRODUCT WARRANTY

Enviro Square Limited (KAPO Calcium Silicate Board) warrants for a period of 20 years from the date of purchase that the KAPO Calcium Silicate Board will be free from manufacturing defects due to defective factory workmanship or materials and, subject to compliance with the conditions below, will be resistant to cracking, rotting, fire and damage from termite attacks. Product information can be located on the company website, [www.envirosquare.com](http://www.envirosquare.com) or are available upon request.

Enviro Square Limited warrants that the Products supplied from manufacturing defect and conform to the products technical data sheet and are fit for their intended purpose as detailed in each products Technical data sheet and the Blush Specification Manual. Product information can be located on the company website, [www.envirosquare.com](http://www.envirosquare.com) or are available upon request.

Nothing in this document shall exclude or modify any legal rights a customer may have under the Consumer Guarantees Act or otherwise which cannot be excluded or modified at law.

### WARRANTY - MANUFACTURING DEFECTS:

The warranty is strictly subject to the following conditions:

- The warranties are only available to the Original Purchaser who provides Enviro Square Ltd with proof of purchase and who makes the claim in writing within 30 days from when the defect should have become apparent.
- the Product must be installed and maintained strictly in accordance with the relevant Enviro Square literature current at the time of installation and must be installed in conjunction with the components or products specified in the literature. Further, all other products, including coating and jointing systems, applied to or used in conjunction with the Product must be applied or installed and maintained strictly in accordance with the relevant manufacturer's instructions and good trade practice;
- the project must be designed and constructed in strict compliance with all relevant provisions of the current New Zealand Building Code ("NZBC"), regulations and standards;
- The remedies provided by Enviro Square for a breach of either of the warranty provided are limited to Enviro Square replacing the Product, subject to such replacement Products being available in the manufacturing inventory at the time the claim is accepted by Enviro Square or at its option Enviro Square will refund the purchase price of the product. The Purchaser is not entitled to any other remedy with respect to a warranty claim.
- Enviro Square will not be liable for any losses or damages (whether direct or indirect) including property damage or personal injury, consequential loss, economic loss or loss of profits, arising in contract or negligence or howsoever arising. Without limiting the foregoing Enviro Square will not be liable for any claims, damages or defects arising from or in any way attributable to poor workmanship, poor design or detailing, settlement or structural movement and/or movement of materials to which the KAPO Calcium Silicate Board is attached, incorrect design of the structure, acts of God including but not limited to earthquakes, cyclones, floods or other severe weather conditions or unusual climatic conditions, efflorescence or performance of paint/coatings applied to the Product, normal wear and tear, growth of mould, mildew, fungi, bacteria, or any organism on any Product surface or Product (whether on the exposed or unexposed surfaces);
- all warranties, conditions, liabilities and obligations other than those specified in this warranty are excluded to the fullest extent allowed by law;
- if meeting a claim under this warranty involves re-coating of Products, there may be slight colour differences between the original and replacement Products due to the effects of weathering and variations in materials over time.



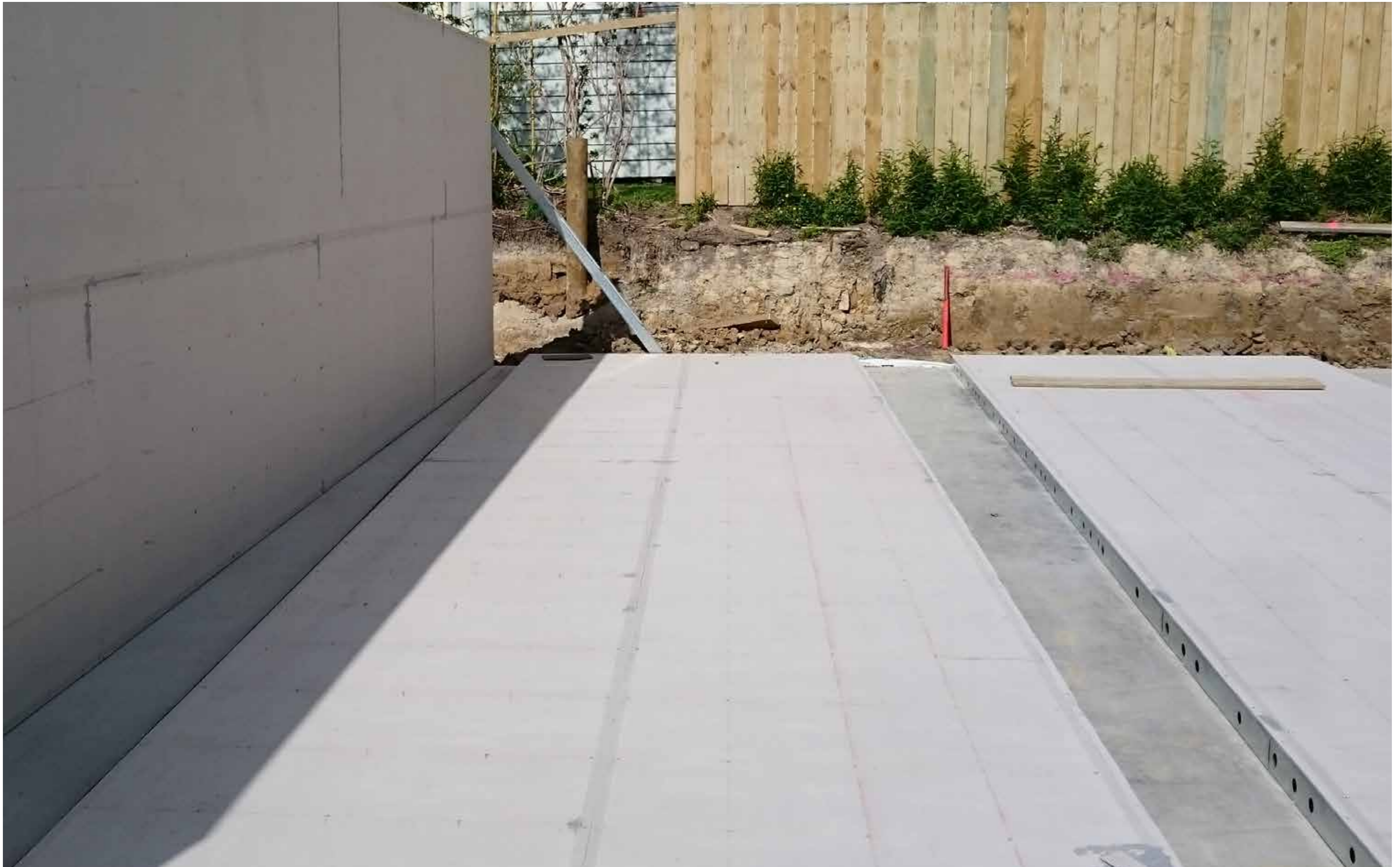

**THANK YOU FOR CHOOSING KAPO BOARD**





enviro square



[enquiry@envirosquare.com](mailto:enquiry@envirosquare.com) | [www.envirosquare.com](http://www.envirosquare.com)

